

HD 650

HD 651

USA
CDN

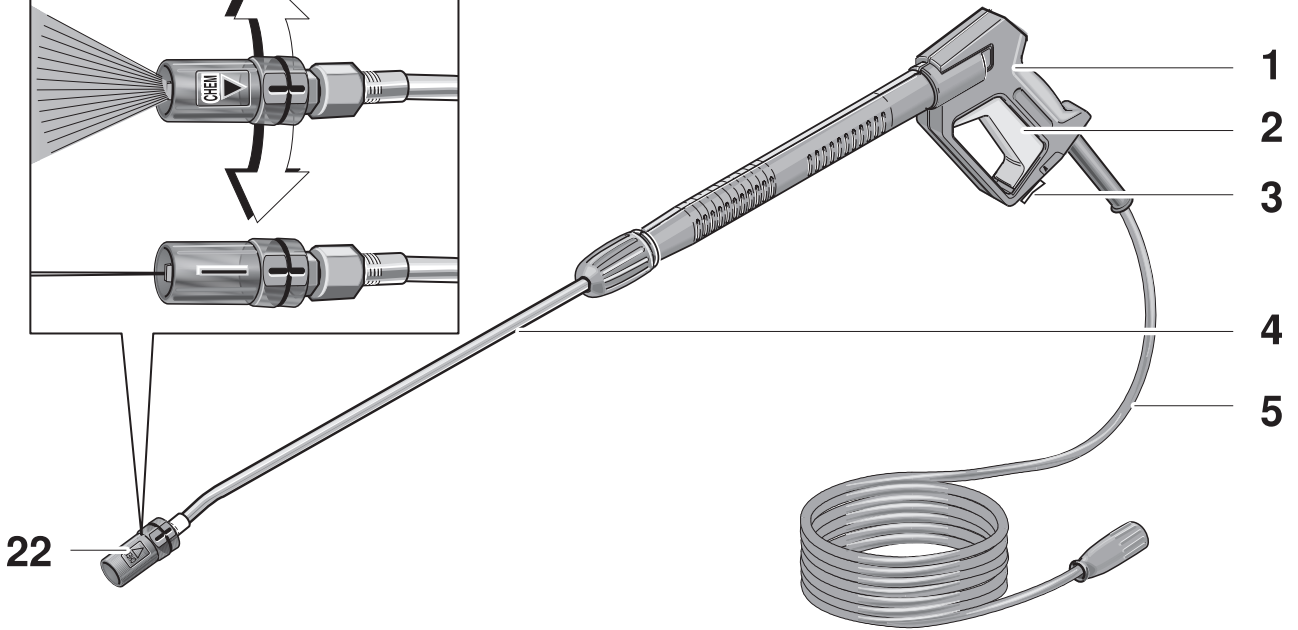
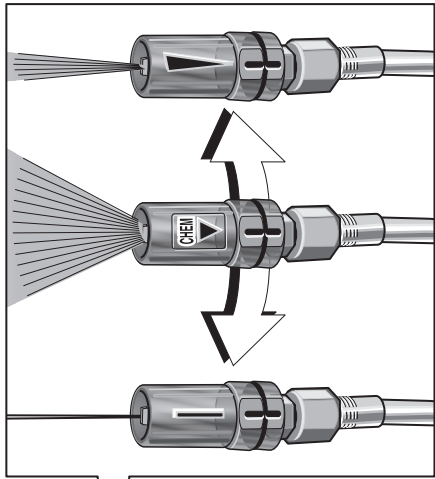

1. Important notice

Unit parts

Please fold out illustration page at the front

- 1 Handgun (with built-in pressure gauge)
- 2 Lever
- 3 Safety switch
- 4 Spray lance
- 5 High-pressure hose
- 6 Handgun support
- 7 Nozzle rest
- 8 Detergent metering valve
- 9 Cap for detergent reservoir
- 10 Detergent reservoir
- 11 Detergent suction-hose with filter
- 12 Fastening screws for unit cover
- 13 Pressure/flow control
- 14 High-pressure outlet
- 15 Water outlet with strainer
- 16 Checkpoint for oil level
- 17 Unit switch
- 18 Hose rest
- 19 Fastening screws for handle
- 20 Cable/hose rest
- 21 Handle
- 22 Nozzle

For your safety

Before you use the cleaner for the first time, read these operating instructions and take special note of the accompanying booklet "Safety Instructions for High-pressure Cleaners" No. 5.951-949.

Use of the cleaner

Use this cleaner exclusively for

- cleaning with high-pressure jet and detergent (e.g. cleaning of machines, vehicles, buildings, tools)
- cleaning with high-pressure jet without detergent (e.g. cleaning facades, terraces, gardening equipment).

For stubborn dirt we recommend the dirt blaster as an optional accessory.

Safety features

Relief valve with pressure switch

On reducing the flow rate with the pressure and flow control, the relief valve opens and part of the water runs back to the suction side of the pump. If the lever (2) is released, the pressure switch switches the pump off. If the lever is retracted, the pressure switch switches the pump on again.

Warning

Do not use with flammable liquids and toxic chemicals.

Injection hazard: Equipment can cause serious injury if the spray penetrates the skin. Do not point the gun at anyone or any part of the body. In case of penetration seek medical aid immediately.

This system is capable of producing *) kpa. To avoid rupture and injury, do not operate this pump with components rated less than *) kpa working pressure (including but not limited to spray guns, hose and hose connections). Before servicing, cleaning or removal any parts, shut off power and relieve pressure.

*) HD 650	2000 psi 14000 kpa
*) HD 651	1500 psi 10500 kpa

Warranty

The warranty terms issued by our authorised marketing company are valid in every country. We remedy any fault in the cleaner free of charge within the warranty period providing the cause of the fault proves to be a material or manufacturing error.

The warranty only becomes operative when your dealer has completed the reply card accompanying the sale of the unit, has stamped and signed it and you have then sent the reply card to the marketing company in your country. Should you wish to call upon the guarantee, please apply to your dealer or nearest authorised Customer Service centre taking along also the accessories and bill of sale.

2. Preparing the cleaner for use

Unpack the cleaner

- When unpacking the cleaner, check the contents of the packaging. If there has been any damage in transit inform the dealer.
- Do not dispose of the packaging with the household rubbish, hand it in at the appropriate collection point for recycling.

Check the oil level

See illustrations **1** to **3** at the end of the instructions.

- Screw out the fastening screws on the left and right of the unit cover, remove unit cover.
- Cut off the tip on the cover to the oil reservoir.
- Check the oil level in the oil reservoir.
- Fasten the unit cover.

Mount the accessories

See illustrations **4** to **6** at the end of the instructions.

- Mount handle (screws and nuts supplied).
- Engage the holder for handgun at the side of the handle.
- Mount nozzle on the spray lance (see markings on the top of the setting ring).
- Mount spray lance on the handgun.

3. Using the cleaner for the first time

Electrical connection

Caution! The voltage specified on the model rating plate must correspond to the voltage supplied.

Caution! Use an extension cable whose cable cross-section is adequate (see "Technical Specifications") and unreel it completely from the cable drum.

- For connected loads see model rating plate/ Technical Specifications

Water connection/suction feed operation

Connection to water main

Caution! Pay attention to the regulations of the water supply company; according to DIN 1988, the cleaner may not be connected direct to the public drinking water supply. A short-term connection via a non-return valve (Order no. 6.412-578) is allowed.

For connected loads see Technical Specifications.

- Connect a supply hose (not supplied) to the water outlet (15) on the cleaner and to the water inlet (e.g. water tap).
- Open water inlet.

Suctioning water from an open container

- Screw suction hose with filter (Order no. 4.440-238) to the water outlet (15).

Venting the unit

- To vent the unit, unscrew the nozzle and leave the unit running until the water exits with no air bubbles.
- Switch off the unit and screw the nozzle back on.

4. Operating the cleaner

Danger! Observe the relative safety regulations when using the cleaner at filling stations or other high-risk areas.

Caution! Only clean engines in places which have appropriate oil separators (protection of the environment).

Caution! Only wash animals with the low-pressure fan jet (see "Selecting the type of spray").

Operating with high pressure

The cleaner is equipped with a pressure switch. The motor only starts up when the lever (2) is retracted.

- Press safety switch (3) and retract lever (2).
- Set unit switch (17) to "I".
- Adjust operating pressure and flow rate (+/-) by rotating the pressure/flow control (13) (infinitely variable).

Read off operating pressure on pressure gauge.

Selecting the type of spray

The handgun must be closed.

- Rotate the housing of the nozzle (22) until the desired symbol corresponds with the marking:

 High-pressure pencil jet for particularly stubborn accumulation of grime

 Low-pressure fan jet for operating with detergent or cleaning with negligible pressure

 High-pressure fan jet for dirt accumulation over a large surface

Operating with detergent

Caution! Unsuitable detergents can harm the cleaner and the object which is to be cleaned. Use only detergents which are released by Kärcher. Proportions of detergent to be used and accompanying instructions should be noted carefully. Use detergents sparingly out of consideration for the environment.

Kärcher cleaning agents guarantee trouble-free operation. Please seek advice or ask for our catalogue of information sheets on cleaning agents.

- Active cleaner RM 31 ASF
- Universal cleaner RM 55 ASF
- Active wash RM 81 ASF

- Fill detergent reservoir (10).
- Set nozzle (22) to  .
- Set detergent metering valve (8) to the centre position. Adjust dosage with + or – as required.

Recommended cleaning methods

1. Spray detergent sparingly over the dry surface to be cleaned and let it take effect but not dry out.
2. Spray off (rinse off) the loosened dirt using the high-pressure spray.

- When you have finished the operation, set detergent metering valve (8) to "0" and switch the cleaner on for about 1 minute and rinse it clear of detergent.

Interrupting the operation

- Release lever (2), the cleaner switches off. Retract lever again and the cleaner switches on again.

Switching the cleaner off

- Set unit switch (17) to "0" and pull out power plug.
- Close water inlet.
- Retract lever (2) until the cleaner is without pressure.
- Press safety switch (3) to secure lever against being activated unintentionally.

Transporting the cleaner

- To transport the cleaner over relatively long stretches, take hold of it by the handle (21) and pull it along behind you.
- To transport it up steps or over ledges pick it up by the handle.
- Empty the detergent reservoir (10) before transporting it horizontally.

Storing the cleaner

- Place the handgun (1) in the support (6).
- Reel in the high-pressure hose (5) and hang it over the hose rest (18).
- Coil the connecting cable round the cable/hose rest (20).

4. Operating the cleaner

Protection from sub-zero temperatures

Caution! Water which has frozen in the cleaner can destroy parts of it. At best store the cleaner in a heated room during the winter or empty it or rinse it thoroughly with antifreeze.

- Empty the cleaner
 - Unscrew supply hose and high-pressure hose from the cleaner.
 - Leave the cleaner running until the pump and lines have emptied (max. 1 minute).
- Putting in antifreeze

For longer intervals between operations, pumping antifreeze through the cleaner is to be recommended. By this means also you obtain a sure protection against corrosion.

5. Care and maintenance

Danger! Before undertaking any care or maintenance work on the cleaner, pull out the power plug.

Caution! When changing the oil, dispose of any waste oil only at authorised collection points.

Safety inspection/maintenance contract

You can arrange with your dealer to have a regular safety inspection carried out or to have a maintenance contract. Please seek advice on this.

Each time before operating the cleaner

- Check connecting cable for damage (risk of getting an electric shock), have a damaged connecting cable replaced without delay by authorised Customer Service personnel or an electrician.
- Check high-pressure hose for damage (danger of explosion), replace a damaged high-pressure hose without delay.

- Check cleaner (pump) for any leaks. Three drops per minute are allowable and can appear on the underside of the cleaner. Seek the help of Customer Service if leaks are more serious.

Every week

- Check oil level in oil reservoir (16): if the oil is milky (water in oil), seek the help of Customer Service immediately.
- Clean the strainer at the water outlet.
- Clean the filter at the suction hose for detergent.

Annually or after 500 operating hours

- Change the oil
 - For oil quantity and type see Technical Specifications.
 - Undo fastening screws (12), remove unit cover, remove cover of oil reservoir.
 - Lay cleaner on its side and drain oil into a suitable container.
 - Fill slowly with fresh oil; air bubbles have to escape.

6. Troubleshooting

Danger! Before any repair work is undertaken, switch the cleaner off and pull out the power plug. Have electrical components checked and repaired only by authorised Customer Service personnel. For faults which are not identified in this chapter, or when in doubt or when expressly instructed to do so, consult authorised Customer Service personnel.

Cleaner does not work

- Check mains voltage.
- Check connecting cable for damage.
- If the motor has overheated, let the cleaner cool down. Then switch it on again.
- Consult Customer Service if there is an electrical fault.

Cleaner does not come up to pressure

- Set nozzle (22) to “high pressure”.
- Clean nozzle or replace with new one.
- Clean strainer at the water connection (15).
- Evacuate air from the cleaner.
- Check water inlet volume (see Technical Specifications).
- Check all supply lines to the pump for leaks or obstructions.
- Seek the help of Customer Service if necessary.

Pump is leaky

- Three drops per minute are allowable and can appear on the underside of the cleaner. Seek the help of Customer Service if leaks are more serious.

Pump makes a knocking noise

- Check all supply lines as well as the detergent system for leaks.
- Evacuate air from the cleaner.
- Seek the help of Customer Service if necessary.

Detergent is not being drawn in

- Set nozzle (22) to “low pressure”.
- Check detergent suction hose (11) with filter for leaks or obstructions and clean it if necessary.
- Clean/renew non-return valve in detergent suction-hose (11) connection.
- Open detergent metering valve (8) or check it for leaks/remove obstruction. Also clean venting orifice in the cap.
- Tip the cleaner backwards over the wheels. Empty the detergent reservoir (10) and rinse it out.
- Seek the help of Customer Service if necessary.

7. Spare parts

You will find a list of spare parts at the end of these operating instructions.

8. Technical Specifications

		<i>HD 650</i>		<i>HD 651</i>	
		<i>1.150-105</i>	<i>1.150-106</i>	<i>1.150-111</i>	<i>1.150-110</i>
Mains connection		CDN	USA	CDN	USA
Voltage	V	240	240	120	110
Type of current	Hz	1~60	1~60	1~60	1~60
Connected load	HP	4.5	4.5	2.8	2.8
Supply fuse (delayed-action)	A	16	16	20	20
Extension cable 10 m	mm ²	1.5	1.5	2.5	2.5
Extension cable 30 m	mm ²	2.5	2.5	2.5	2.5
Water connection					
Supply temperature (max.)	°C	60	60	60	60
Supply volume (min.)	gpm	3.1	3.1	3.1	3.1
Supply hose – length	m	7.5	7.5	7.5	7.5
Supply hose – minimum diameter	inches	1/2	1/2	1/2	1/2
Suction height from an open container 20 °C	m	0.5	0.5	0.5	0.5
Supply pressure (max.)	psi	140	140	140	140
Performance data		kpa	psi	kpa	psi
Operating pressure		2000–14000	300–2000	2000–10500	300–1500
Flow rate	gpm	1.1–3.0	1.1–3.0	1.1–2.3	1.1–2.3
Detergent intake	gpm	0–0.17	0–0.17	0–0.17	0–0.17
Recoil force of the handgun	N	26	26	26	26
Sound level (DIN 45 635)	dB(A)	78	78	78	78
Dimensions					
Length	mm	400	400	400	400
Width	mm	340	340	340	340
Height	mm	900	900	900	900
Weight without accessories	kg	26.5	26.5	26.5	26.5
Reservoir capacity, detergent	l	7	7	7	7
Oil quantity, pump	l	0.4	0.4	0.4	0.4
Oil type, pump		motor oil 15W40			

KÄRCHER HD 650

1.150-105 CSA-CDN
1.150-106 USA

KÄRCHER HD 651

1.150-110 CSA-CDN
1.150-111 USA

